

No. 649,356.

Patented May 8, 1900.

F. A. RICHTER.

MEANS FOR HOLDING NOTE DISKS OF MECHANICAL MUSICAL INSTRUMENTS.

(Application filed Dec. 23, 1899.)

(No Model.)

4 Sheets—Sheet 1.

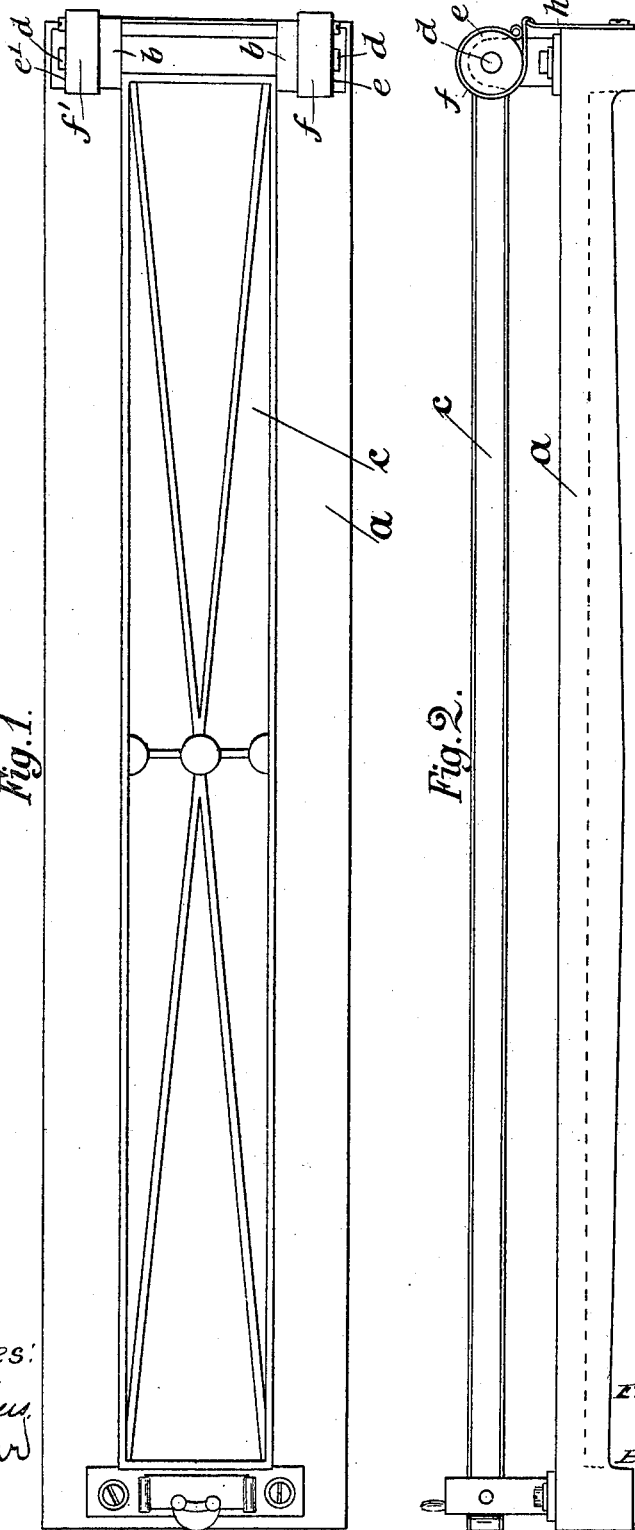

witnesses:  
*H. Lee Helms*  
*W. Parker*

Inventor  
*Friedrich A. Richter*  
 By *James L. Norris*  
 Atty

No. 649,356.

Patented May 8, 1900.

F. A. RICHTER.

MEANS FOR HOLDING NOTE DISKS OF MECHANICAL MUSICAL INSTRUMENTS.

(Application filed Dec. 23, 1899.)

(No Model.)

4 Sheets—Sheet 2.

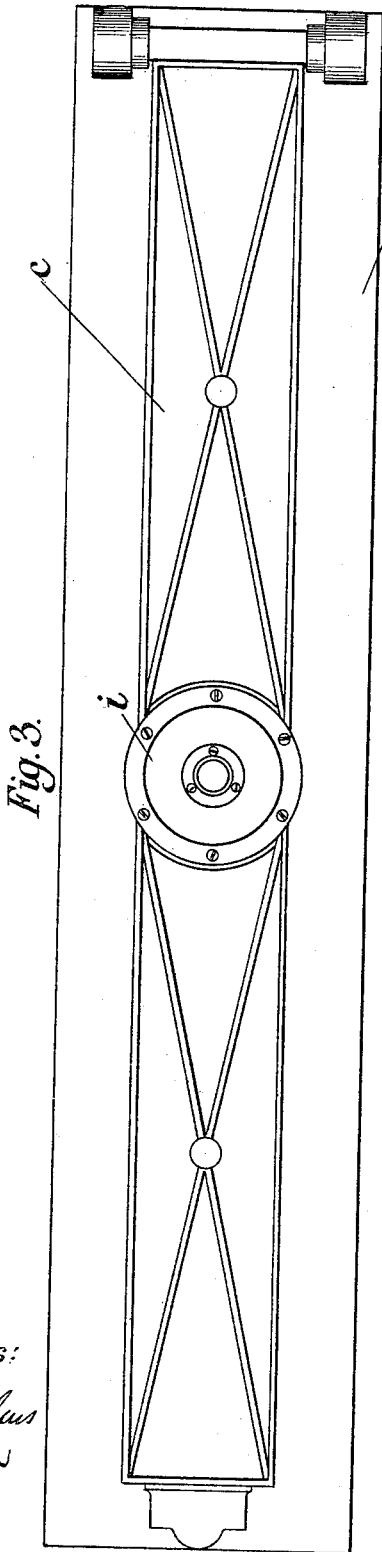

Fig. 3.

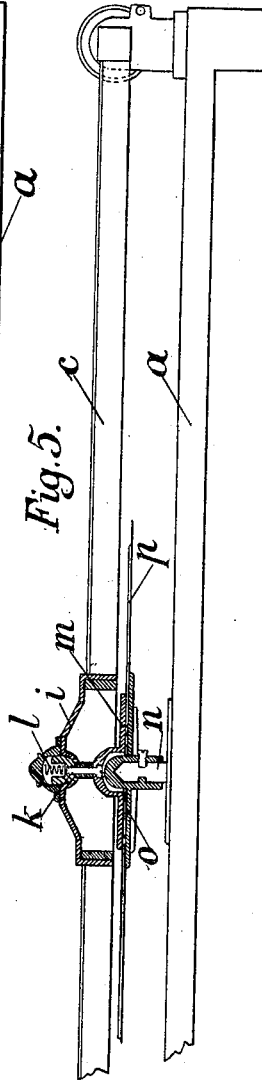

Fig. 5.

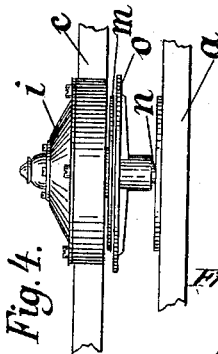

Fig. 4.

Witnesses:  
*W. Lee Helms*  
*and Parker*

Inventor  
*Friedrich A. Richter*

By *James L. Norris*  
 Atty.

F. A. RICHTER.

MEANS FOR HOLDING NOTE DISKS OF MECHANICAL MUSICAL INSTRUMENTS.

(Application filed Dec. 23, 1899.)

(No Model.)

4 Sheets—Sheet 3.

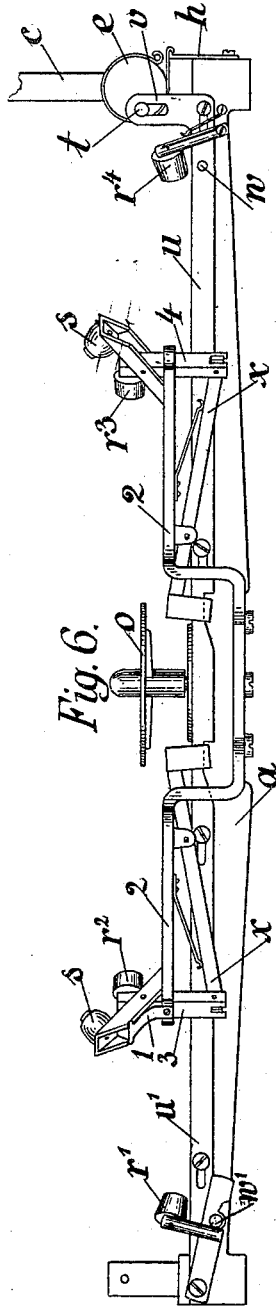

Fig. 6.

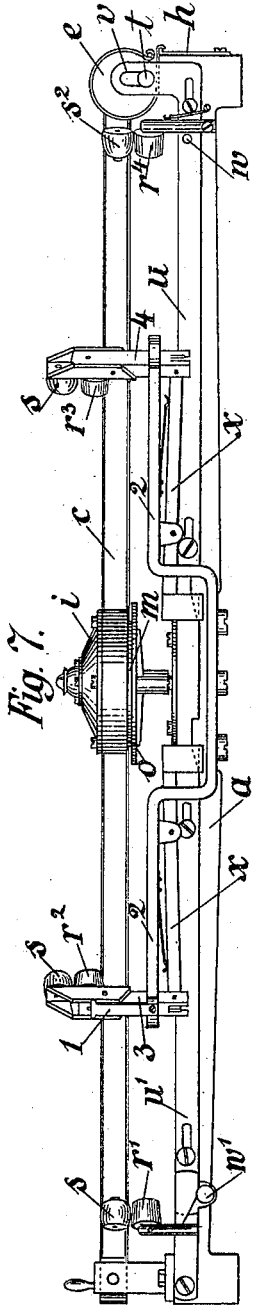

Fig. 7.

Witnesses:  
*W. Lee Helms*  
*W. Parker*

Inventor  
*Friedrich A. Richter*  
 By *James L. Norris*  
 Atty

No. 649,356.

Patented May 8, 1900.

F. A. RICHTER.

MEANS FOR HOLDING NOTE DISKS OF MECHANICAL MUSICAL INSTRUMENTS.

(Application filed Dec. 23, 1899.)

(No Model.)

4 Sheets—Sheet 4.

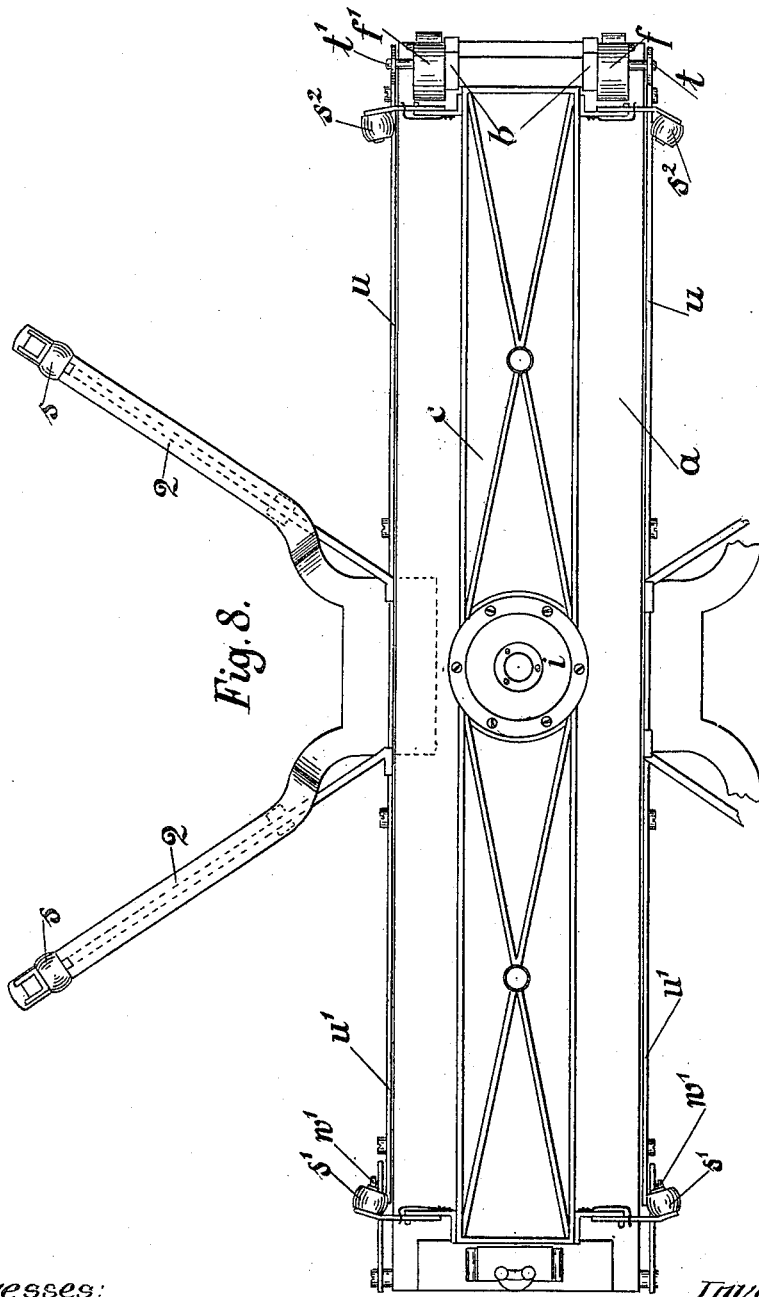

Fig. 8.

Witnesses:  
N. Lee Helges  
S. Parker

Inventor  
Friedrich A. Richter

By James L. Norris.  
Atty.

# UNITED STATES PATENT OFFICE.

FRIEDRICH ADOLF RICHTER, OF RUDOLSTADT, GERMANY.

MEANS FOR HOLDING NOTE-DISKS OF MECHANICAL MUSICAL INSTRUMENTS.

SPECIFICATION forming part of Letters Patent No. 649,356, dated May 8, 1900.

Application filed December 23, 1899. Serial No. 741,469. (No model.)

*To all whom it may concern:*

Be it known that I, FRIEDRICH ADOLF RICHTER, a subject of the King of Bavaria, residing at Rudolstadt, in the Principality of Schwarzburg-Rudolstadt, German Empire, have invented a certain new and useful Improvement in Means for Holding the Note-Disks in Mechanical Musical Instruments, of which the following is a specification.

This invention relates to mechanical musical instruments of the class in which the reeds are operated by levers, star-wheels, or the like actuated by slots or tongues provided in or on the face of a circular, preferably a metallic, disk, more generally known under the term of "note-sheet" or "note-disk," said note-disk being adapted to be placed on the horizontal plate of usual and well-known construction carried by a spring-actuated vertical or main shaft of the instrument, so as to rotate therewith, thereby actuating the playing levers or wheels or the like and to allow the note-disk of being removed therefrom at any time.

The object of this invention is to provide means for allowing the disk to be readily placed on and removed from the instrument, especially for efficiently maintaining at any position, vertical or inclined, the arm or holder provided for holding the note-disk on said plate, and, further, to provide special means operated by said holder for bending, holding, and guiding the note-disk in proper position when the tune is being played, said means being simple in construction and at the same time adapted to operate satisfactorily in that the disk will be allowed to be placed on the parts of the instrument provided for supporting the disk without thereby becoming deformed or uneven, and again to be easily removed therefrom and replaced by another.

To this end my invention consists in the arrangement and construction of parts more fully hereinafter specified, and shown in the accompanying drawings, said parts comprising, essentially, an arm or holder with one end hinged or pivotally connected to the frame in the usual manner, said holder being provided with a friction device at its hinged end for maintaining the holder in any desired position when turned upward, and, further, comprising a rotary disk provided in the holder

and a series of pairs of rolls operated by the holder for evenly holding, bending, and guiding the note-disk in a manner required for efficiently actuating the playing mechanism without thereby producing that disturbing noise caused in the instruments heretofore known by the undulatory movement of the disk.

The friction device at the hinged end of the holder consists of one or two disks attached to the elongated pins or pivots of the holder and provided with a brake-strap or with two such straps, respectively, with one end connected to a spring fixed to the frame and the other end attached to the frame itself. The means for holding, bending, and guiding the disk in accordance with and in dependency on the movement of the holder consist, respectively, of a rotary disk arranged in the middle of the arm or holder, (provided that the holder is made of such a length as to extend over the note-disk from end to end,) so as to press upon and hold the central portion of the note-disk as the holder is turned downward into its locking position, thereby cooperating with said rotary disk to keep the note-disk in proper position for actuating the playing mechanism, and of a lever and sliding-rolls arrangement controlled by and cooperating with said holder for holding, bending, and guiding the marginal part of the note-disk in accordance with and in dependence upon the movement and position of the holder. In case that the holder will be made only of about half the length of the diameter of the note-disk the rotary disk will be provided at the inner or free end of the holder.

In the drawings illustrating the invention, Figures 1 and 2 are respectively a plan and an elevation of the arm or holder in closed position on the frame. Fig. 3 is a plan of the holder provided with the rotary disk in the middle thereof. Fig. 4 is an elevation of the middle portion of the latter with the lateral parts broken away; and Fig. 5 is an elevation of the holder shown in Fig. 3, partly in section and with some of the parts broken away. Fig. 6 is an elevation of the guiding or holding and bending device operated by and cooperating with the holder shown in open or raised position, the fore part of the latter being broken away. Fig. 7 is a similar view

with the parts in closed position, and Fig. 8 is a plan according to Fig. 7 with certain parts broken away.

The arm or holder *c* (see Figs. 1 and 2) is 5 hinged or pivotally connected to the posts *b* on the bottom plate *a*, forming the frame, by means of the pins or pivots *d*, extending from the holder through holes provided in the posts for the purpose. On the projecting ends of 10 the pins and in proximity to the posts disks *e* and *e'*, respectively, are mounted, separate straps *f* and *f'*, with one of their ends attached to the posts and with the other end to the free ends of strong springs *h*, being laid around 15 the disks, so that the said straps will exert under the influence of the springs a braking strain or a frictional stopping effect on the disks, and consequently on the holder as the latter is turned on its pivot. By these means 20 the holder will be enabled to maintain or keep any inclined or erect position into which it will be brought without requiring any special abutment or any other device affording a stop to the holder when thus removed from 25 its horizontal or locking position.

It is obvious that in lieu of the two disks I may use a single disk without thereby departing from the nature of my invention, and said single disk may be mounted on either of 30 the two pivots of the holder or otherwise may be arranged in the middle of the pin or axle forming the pivots of the holder. In this case the end of the latter must be properly recessed, so as to form two branches between 35 which the disk is arranged on the pin with the ends of the latter held by said branches.

In order to prevent the note-disk from any undulatory movements causing disturbing noises during its rotation, I provide in the 40 holder a disk *m*, with a central bowl fitting snugly the prominent central part of the base-plate *o*, covering the top of the vertical shaft *n* (see Figs. 4 and 5) and serving as a support for the central portion of the note-disk. 45 From said disk *m* an arm projects upward, connecting the disk by means of a ball-and-socket joint *k* to the circular casing *i*, forming the middle portion of the holder, a spring *l* being provided in the socket, operating to 50 press the disk *m* downward toward the base-plate *o*. Supposing the note-disk *p* to have been placed on the plate *o* and the holder *c* to be then turned downward and locked at its free end, it will be seen that the disk *m* 55 under the pressure of the spring *l* will uninterruptedly bear against the central portion of the note-disk, thereby causing the latter to lie flat and even on the base-plate *o* and to remain under tension all the time the instrument is playing, notwithstanding the tendency for undulatory movements arising in the note-disk from the rotary movements imparted thereto while being carried around together with the plate *o* and the disk *m*.

The lever and bending-rolls arrangement 65 operated by the holder consist of a pair of bent levers or bars *u* and *u'*, (see Figs. 6, 7,

and 8,) guided so that when the holder is being turned upward the pins *t*, provided on the outer faces of the disks *e* and *e'*, cooperate 70 with the slots *v* in the vertical arm of said levers, so that the latter will be pushed forward and be retracted again when the holder is returned to its horizontal or locking position. At the ends of the bottom plate *a* 75 there are two pairs of arms suitably hinged to the plate, each of said arms carrying a roll *r'* *r''* at its free end. Owing to their gravity or to springs provided for this purpose, said arms assume a low or inclined position (see 80 Fig. 6) when the holder is turned upward, but will be erected and brought to a more or less vertical position (see Fig. 7) by the pins *w* and *w'*, respectively provided on the levers *u* and *u'* and pressing toward said arms when 85 the holder is turned downward again, so that said rolls cooperate with the rolls *s'* and *s''*, provided for on either end of the holder to bend, hold, and guide the note-disk placed between them. All the time the rolls *r'* and 90 *r''*, arranged at the ends of the bottom plate, are actuated so as to change their position in accordance with and in dependence upon the position of the holder the levers *u* and *u'* also act upon a set of suitably-arranged levers, 95 preferably four in number and carried by four branches of the bottom plate *a*, so that four sets of guiding-rolls, suitably provided at the ends of said branches, will cooperate with the rolls *r'* *r''* to hold, bend, and guide the note- 100 disk when a tune is being played. The mechanism operating said four sets of rolls (shown in Figs. 6 to 8) consists of the levers *x*, supported by the branches 2 of the bottom plate and having noses at one end extending to- 105 ward and embracing the bars and carrying at their other ends short arms 3 and 4, provided with rolls *r<sup>2</sup>* and *r<sup>3</sup>*, respectively, at its upper end, and with a sliding lever pivotally connected to the arms 3 and 4, extending through 110 holes in the ends of the branches, said sliding levers carrying likewise rolls *s* at their upper ends.

When the holder *c* is given an upright or inclined position, the noses of the levers *x* 115 embrace the horizontal arms of the bent levers *u* *u'* at a point where the latter are recessed, (see Fig. 6,) so as to allow the outer arms of the levers, and hence the rolls *r<sup>2</sup>* and *r<sup>3</sup>*, to assume a low position owing to the pressure of springs attached to the branches and acting with their free ends upon the levers. 120 At the same time the sliding levers carried by the arms 3 and 4 descend and are forced to slide with their tapered lower ends on the 125 upper surface of the branches 2, so that the rolls *s*, carried by said levers, move outside in radial direction and away from the rolls *r<sup>2</sup>* *r<sup>3</sup>*, thus allowing the note-disk to be removed from the instrument and to be replaced 130 by another. When the holder is turned back again to the horizontal or locking position, the aforesaid bars *u* *u'* take the position shown in Fig. 7, thereby allowing the levers *x* to return

to the horizontal position under the action of their springs, and, further, allowing the sliding levers to slide back to their vertical position under the action of their springs *l*, so that the rolls *s* come again in contact with the rolls *r*<sup>2</sup> *r*<sup>3</sup> or with the note-disk placed upon the latter, thereby assisting to hold, bend, and guide the disk, so as to prevent it from undulatory movements when rotating while the instrument is playing. It is obvious that in doing this the said four sets of rolls cooperate with the sets of rolls provided at either end of the holder and of the bottom plate, and, further, from the described mode of operation of the said cooperating sets of rolls it will be seen that a holding, bending, and guiding device of this kind is by far more efficient in use than the devices heretofore known for the purpose, and consisting, essentially, of sets of rolls, the lower of which are fixed rolls—that is to say, rolls unchangeable in their vertical positions. Rolls of this kind evidently are most inconvenient as regards the difficulties existing in placing a note-disk of a large size between the guiding-rolls, and, further, as regards the inconveniences consisting in that a large disk tends to become uneven when being placed on and guided by said fixed rolls.

I wish it to be understood that I do not confine myself to the exact details of construction or arrangement described and shown, as these admit of various modifications and variations within the scope of this invention.

Having thus fully described my invention, what I desire to claim and secure by Letters Patent is—

1. A mechanical musical instrument comprising a mechanism for producing tunes from a circular note-disk, and a device for holding the note-disk in proper position on the parts supporting the disk, said device consisting of an arm or holder having a frictional brake at its hinged end for maintaining the holder when in open position and a rotary disk at the part thereof corresponding to the center of the note-disk for holding and guiding the central part of the note-disk and of a series of pairs of rolls operated by the holder so as to change their position in vertical direction and cooperating therewith to hold and guide the note-disk, substantially as described.

2. In a mechanical musical instrument having a mechanism for producing tunes from a circular note-disk, the combination of an arm or holder having at its hinged end one or more disks with a spring-controlled brake-strap thereon for maintaining the holder in any upright or inclined position given to the holder on disengaging it from the note-disk, substantially as described.

3. In a mechanical musical instrument having a mechanism for producing tunes from a circular note-disk, the combination of an arm or holder with one end hinged to the bottom plate, a rotary disk connected to the holder by a ball-and-socket joint, a spring provided in said joint between said ball and the socket

and a base-plate provided on the vertical or main shaft of the instrument to support the note-disk so as to allow the spring-controlled rotary disk to press the central portion of the note-disk gently and evenly toward the said base-plate, substantially as described.

4. In a mechanical musical instrument having a mechanism for producing tunes from a circular note-disk, the combination of an arm or holder having at its hinged end one or more disks with a brake-strap thereon, and having a rotary disk connected to the holder by a ball-and-socket joint to hold flat the central part of the note-disk, during the play of the instrument, substantially as described.

5. In a mechanical musical instrument having a mechanism for producing tunes from a circular note-disk, the combination with an arm or holder with one end hinged to the bottom plate, of a series of pairs of rolls arranged at different points of the frame corresponding to the circumferential line of the note-disk, and means actuated by said holder for causing the rollers to approach and recede from each other, substantially as described.

6. In a mechanical musical instrument having a mechanism for producing tunes from a circular note-disk, the combination with an arm or holder with one end hinged to the bottom plate, of a rotary disk connected to the holder by a ball-and-socket joint, a series of pairs of rollers arranged at different points of the frame corresponding to the circumferential line of the note-disk, and means actuated by said holder for causing the rollers to approach and recede from each other, substantially as described.

7. In a mechanical musical instrument having a mechanism for producing tunes from a circular note-disk, the combination of an arm or holder having at its hinged end one or more disks as described with a spring-controlled brake-strap thereon for maintaining the holder in any upright or inclined position given to the holder on disengaging it from the note-disk, a series of pairs of rollers arranged at different points of the frame corresponding to the circumferential line of the note-disk and means actuated by said holder for causing the rollers to approach and recede from each other, substantially as described.

8. In a mechanical musical instrument having a mechanism for producing tunes from a circular note-disk the combination with an arm or holder having at its hinged end one or more disks as described with a brake-strap thereon, and having a rotary disk connected to the holder by a spring-controlled ball-and-socket joint to hold and guide the central part of the note-disk, of a series of pairs of rolls operated by said holder and cooperating therewith to hold and guide the marginal part of the note-disk, substantially as described.

9. In a mechanical musical instrument having a mechanism for producing tunes from a circular note-disk the combination with an arm or holder having at its hinged end one or

more disks as described with a brake-strap thereon, and having a rotary disk connected to the holder by a spring-controlled ball-and-socket joint to hold and guide the central part of the note-disk, of a series of pairs of rolls arranged at different points of the frame corresponding to the circumferential line of the note-disk and means actuated by said holder for causing the rollers to approach and recede from each other, substantially as described.

10. In a mechanical musical instrument having a mechanism for producing tunes from a circular note-disk the combination with an arm or holder with one end hinged to the bottom plate, of a series of pairs of rolls arranged at each end of the bottom plate and of the holder and at the free ends of branches projecting from the bottom plate, and means actuated by said holder for causing the rollers to approach and recede from each other, substantially as described.

11. In a mechanical musical instrument having a mechanism for producing tunes from a circular note-disk the combination with an arm or holder having at its hinged end one or more disks as described with a spring-controlled brake-strap thereon for maintaining the holder in any desired upright or inclined position given to the holder on disengaging it from the note-disk, of a series of pairs of rolls arranged at each end of the bottom plate and of the holder and at the free ends of branches projecting from the bottom plate, and means actuated by said holder for causing the rollers to approach and recede from each other, substantially as described.

12. In a mechanical musical instrument having a mechanism for producing tunes from a circular note-disk the combination with an arm or holder with one end hinged to the bot-

tom plate, of a rotary disk connected to the holder by a ball-and-socket joint, a spring provided in said joint between the ball and the socket, a base-plate provided on the vertical or main shaft of the instrument to support the note-disk so as to allow the rotary disk to press the central portion of the note-disk toward the base-plate, and a series of pairs of rolls arranged at each end of the bottom plate and of the holder and at the free ends of branches projecting from the bottom plate, and means actuated by said holder for causing the rollers to approach and recede from each other, substantially as described.

13. In a mechanical musical instrument having a mechanism for producing tunes from a circular note-disk the combination with an arm or holder having at its hinged end one or more disks as described with a spring-controlled brake-strap thereon, of a rotary disk connected to the holder by a ball-and-socket joint, a spring provided in said joint between the ball and the socket, a base-plate provided on the vertical or main shaft of the instrument to support the note-disk so as to allow the rotary disk to press the central portion of the note-disk toward the base-plate, and a series of pairs of rolls arranged at each end of the bottom plate and of the holder and at the free ends of branches projecting from the bottom plate, and means actuated by said holder for causing the rollers to approach and recede from each other, substantially as described.

In testimony whereof I have signed my name to this specification in the presence of two subscribing witnesses.

FRIEDRICH ADOLF RICHTER.

Witnesses:

ROBERT R. SCHMIDT,  
ALBERT MASCHKE.